



Cateye vectra
CYCLOCOMPUTER
MODEL CC-7000



INSTRUCTION MANUAL
MODE D'EMPLOI
BETRIEBSANLEITUNG
BEDIENINGSHANDLEIDING
ISTRUZIONI

**OPERATING INSTRUCTIONS
CATEYE VECTRA MODEL CC-7000
CAT EYE CO., LTD.
JAPAN**

INDEX

1. Main Unit	3
2. Accessories	4
3. Measuring and Display Functions	5
4. Button Functions	8
5. Main Unit Preparation	9
6. Magnet/Sensor Mounting	12
7. Bracket Mounting	13
8. Securing the Wire	14
9. Main Unit Mounting	15
10. Test	15
11. How to read data	16
12. Trouble Shooting	17

Introduction

Thank you very much for purchasing a CATEYE VECTRA CYCLOCOMPUTER Model CC-7000. This cyclocomputer not only can display speed but also measures, stores, and displays maximum speed, total distance, trip distance, average speed and elapsed time. Set the distance scale (mile or km) and wheel circumference for your bike. Before operating, thoroughly familiarize yourself with this manual so you completely understand the functions of the cyclocomputer, and enjoy computerized cycling. Store this manual in a safe place for future reference.

1 Main Unit

Front view of main unit

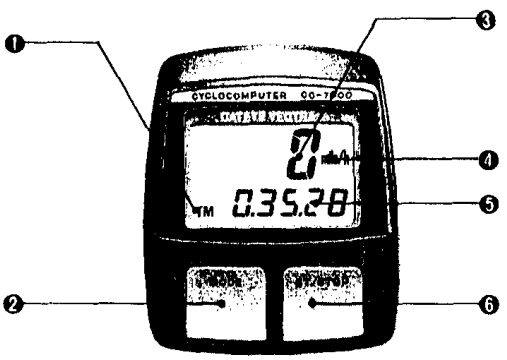

Back view of main unit

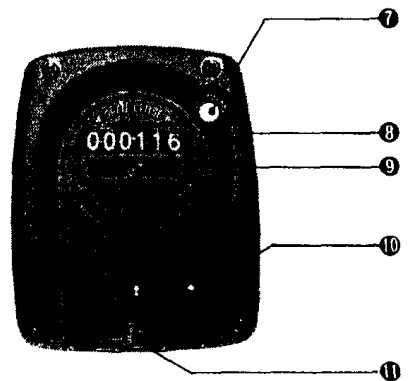

- ① Mode symbol
- ② Mode button
- ③ Speed display
- ④ Speed scale symbol
- ⑤ Selected function display
- ⑥ Start/stop button
- ⑦ AC button
- ⑧ Serial No.
- ⑨ Battery case cover
- ⑩ Contact
- ⑪ Depression

2 Accessories

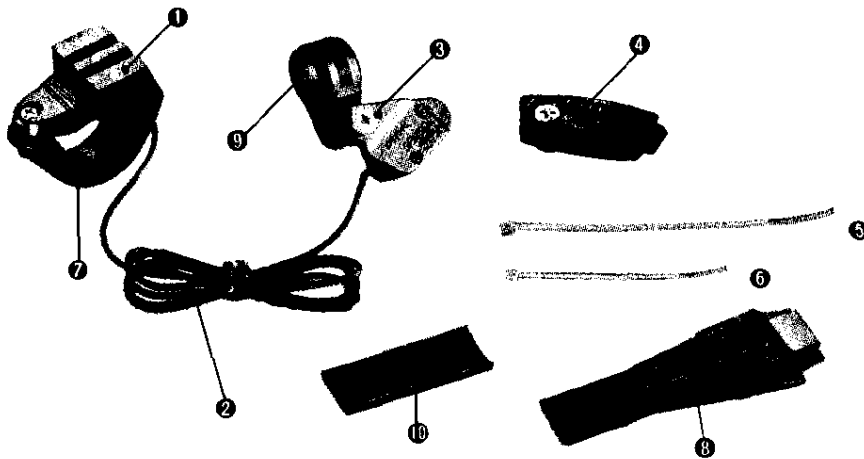

- ① Bracket
- ② Wire
- ③ Sensor
- ④ Magnet
- ⑤ Wire clip, large (3 pieces)
- ⑥ Wire clip, small (1 piece)
- ⑦ Bracket rubber pad (1 mm)
- ⑧ Bracket rubber pad (2 mm)
- ⑨ Sensor band rubber pad (1 mm)
- ⑩ Sensor band rubber pad (2 mm)

3 Measuring and Display Functions

SPD Current Speed

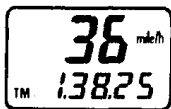

The current speed is displayed on the upper line of the display and updated once a second over a range of 0(3) to 65 miles/h. (0(4) to 105 km/h). The upper limit of measurable speed depends on the wheel size as shown in the table.

1	Wheel size	(inch)	20	22	24	26	27	28
2	Wheel circumference	(cm)	160	176	192	208	216	224
3	Speed limit	(mile/h)	48	53	58	63	65	68
		(Km/h)	78	86	93	101	105	109

MXS **Maximum Speed**

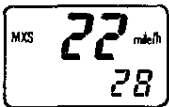

The maximum speed is stored in memory and displayed on the lower line of the display. Measurable in the range of 0(3) to 65 miles/h. (0(4) to 105 km/h). The upper limit is the same as the current speed.

ODO **Total Distance (Odometer)**



The total distance is continuously measured, accumulated and displayed on the lower line of the display until the battery wears down. The range is 0.0 to 9999.9 miles (km) in 0.1 mile (km) increments. When 10,000 miles (km) are reached, the odometer returns to zero and counting begins anew.

DST **Trip Distance**

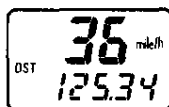

The trip distance from the starting point to the current point is calculated and displayed on the lower line of the display. The range is 0.00 to 999.99 miles (km) in 0.01 mile (km) increments. When 1,000 miles (km) are reached, the trip distance returns to zero and counting begins anew.

AVS Average Speed

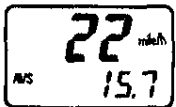

The average speed is calculated on the basis of the elapsed time and the trip distance from the starting point to the current point, and displayed on the lower line of the display. Measurable up to 27 hours 46 minutes 39 seconds (99,999 seconds) for the elapsed time or 999.99 miles (km) for the trip distance. If either is exceeded, E is displayed and calculation ceases.

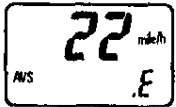

TM Elapsed Time



The elapsed time is measured from the starting point to the current point, and displayed on the lower line of the display in units of hours, minutes and seconds. The range is 0:00:00 to 9:59:59 in second increments. When 10 hours have elapsed, the counter returns to zero and time calculation is restarted.

4 Button Functions

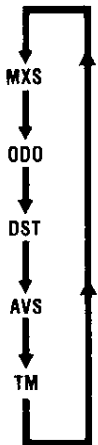

Mode Button (MODE)

The display mode mark shifts in the illustrated sequence each since the button is pressed, and the corresponding data is simultaneously displayed on the lower line of the display.

Start/Stop Button (ST./STOP)

Measurement of the trip distance and elapsed time is simultaneously started or stopped when the start/stop button is pressed. During operation the speed scale symbol flashes.

AC Button (AC)

This button is used when executing "All Clear" operation.

● RESET:

Select any mode except total distance (ODO), and press the mode button and start/stop button simultaneously. (Maximum speed (MXS), trip distance (DST), average speed (AVS) and elapsed time (TM) should be zero.)

● ALL CLEAR:

When the mode button, start/stop button, and AC button are pressed simultaneously, all data stored in memory (including ODO and wheel circumference data) are cleared, all displays illuminate for 2 seconds, then the mile/h symbol illuminates.

This operation should only be executed after replacing the battery or when irregular display of information occurs. Since all the memories are erased, set the distance scale and wheel circumference again according to "Main Unit Preparation" (Page 9, 10).

5 Main Unit Preparation

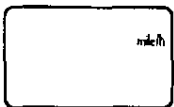

(Fig. 1)

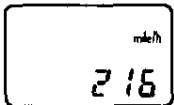

(Fig. 2)

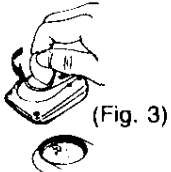

(Fig. 3)

- The following must be completed before operating.
(A battery is already loaded in the main unit when purchased.)

- **Setting the distance scale**

Press all three buttons simultaneously (AC button, mode button and start/stop button) to clear all data. All displays will illuminate for 2 seconds. Then mile/h alone will be displayed as illustrated in Fig. 1. Km/h and mile/h are alternately displayed each time the start/stop button is pressed. Select either as desired. Next, press the mode button, and the distance scale will be set and displayed as shown in Fig. 2.

- * **How to replace the battery**

Turn the main unit over, remove the battery case cover using coin or similar opener as illustrated in Fig. 3, and insert a new lithium battery (CR 2032). Positioning the (+) pole upward as illustrated, place the battery properly into the case and close the cover securely.

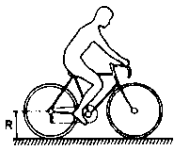

(Fig. 4)

○ **Setting the wheel circumference**

(1) How to measure wheel circumference

Measure the radius R (cm) with the rider on the bicycle as shown in Fig. 4, and calculate the wheel circumference

L (cm) using the following formula:

$$L = 2\pi R = 6.283 R \text{ (cm)}$$

Or, paint a mark on the ground contact surface of the wheel, and directly obtain the wheel circumference by measuring the distance between the marks printed on the ground.

* Table 1 shows R (cm), L (cm) and wheel diameter (inch).

(2) Setting the wheel circumference

216 (standard wheel circumference (cm) for 27" wheel) is displayed as shown in Fig. 2. When using 216 without revision, press the mode button, and (ODO) will be displayed, and 216 is set. To revise 216, press the start/stop button when the wheel circumference is initially displayed, and 216 will be changed to a flickering 217. Then, the number will increase by 1 every time the start/stop button is pressed.

When the button is held down, it will rapidly increase.

Select a number in the range of 130 to 229, according to your bicycle. When the desired number appears, press the mode button. When (ODO) appears, preparation is completed.

(3) Resetting or changing the wheel circumference

Get the stop state in the (ODO) mode, and press the mode button and the AC button simultaneously. The wheel circumference number stored will flicker on the lower line of the display. Revise the number as required according to the instructions given in (?).

* The stored wheel circumference number is displayed while the mode and start/stop buttons are simultaneously pressed in the (ODO) mode.

Table 1. Setting Values Cross Reference Table

						R (cm) Radius	L (cm) Circumference	D (inch) Tire diameter			
R (cm)	L (cm)	D (inch)	R (cm)	L (cm)	D (inch)	R (cm)	L (cm)	D (inch)	R (cm)	L (cm)	D (inch)
25,4~5	160	20,0	28,3~4	178	¼	31,1~2	196	½	34,0~1	214	¾ 700×28C
25,6~7	161	⅙	28,5	179	⅓	31,3	197	⅝	34,2	215	⅞
25,8	162	¼	28,6~7	180	½	31,4~5	198	¾	34,3~4	216	27,0 700×32C
25,9~26,0	163	⅓	28,8	181	⅔	31,6~7	199	⅞	34,5~6	217	⅞
26,1	164	½	28,9~29,0	182	¾	31,8	200	25,0	34,7	218	¼
26,2~3	165	⅔	29,1~2	183	⅞	31,9~32,0	201	⅞	34,8~9	219	⅓
26,4	166	¾	29,3	184	23,0	32,1~2	202	¼	35,0	220	½
26,5~6	167	⅞	29,4~5	185	⅞	32,3	203	⅔	35,1~2	221	⅔
26,7~8	168	21,0	29,6	186	¼	32,4~5	204	½	35,3~4	222	¾
26,9	169	⅞	29,7~8	187	⅔	32,6~7	205	⅔	35,5	223	⅞
27,0~1	170	¼	29,9~30,0	188	½	32,8	206	¾	35,6~7	224	28,0 700B
27,2	171	⅓	30,1	189	⅔	32,9~33,0	207	⅞	35,8	225	⅞
27,3~4	172	½	30,2~3	190	¾	33,1	208	26,0 650A	35,9~36,0	226	¼
27,5~6	173	⅔	30,4	191	⅞	33,2~3	209	⅞ 650B	36,1~2	227	⅓
27,7	174	¾	30,5	192	24,0	33,4~5	210	¼ 700×25C	36,3	228	½
27,8~9	175	⅞	30,6~7	193	⅞	33,6	211	⅔	36,4~5	229	⅔
28,0	176	22,0	30,8~9	194	¼	33,7~8	212	½ * Tubular			
28,1~2	177	⅞	31,0	195	⅔	33,9	213	⅞			

6 Magnet/Sensor Mounting

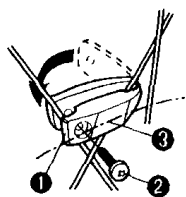

(Fig. 5)

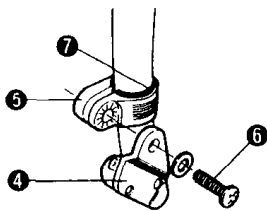

(Fig. 6)

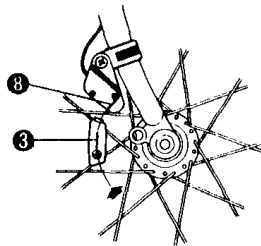

(Fig. 7)

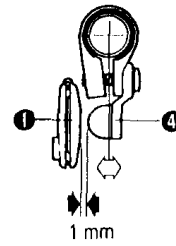

(Fig. 8)

- ① Magnet
- ② Screw
- ③ Center of Magnet
- ④ Sensor
- ⑤ Sensor band
- ⑥ Screw
- ⑦ Rubber pad
- ⑧ Marking line

- (1) Attach the magnet by clamping the right spokes of the front wheel as shown in Fig. 5.
- (2) Attach the sensor on the right side of the front fork. Use either the 1 mm- or the 2 mm-thick rubber pad, whichever matches the tube diameter of your bicycle as shown in Fig. 6, and lightly fasten the screw to allow position adjustment of the sensor. Suitably position the magnet and the sensor, referring to Fig. 7.
- (3) Align the center of magnet and the marking line of sensor. Make sure there is about 1 mm clearance between them. Then, tighten the screw securely. (See Fig. 7 and Fig. 8.)

7 Bracket Mounting

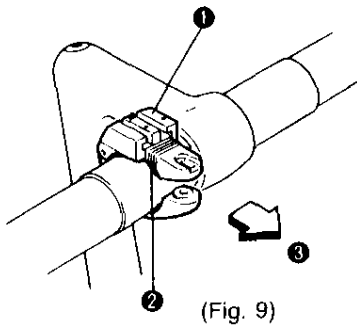

- ① Bracket
- ② Rubber pad
- ③ Front

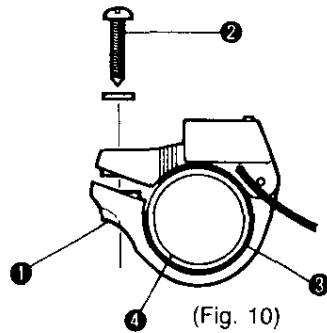

- ① Nut
- ② Screw
- ③ Rubber pad
- ④ Handlebar

Use either the 1 mm- or the 2 mm-thick rubber pad if necessary, according to the handlebar diameter. Attach the bracket close to the handlebar stem as shown in Fig. 9, and tighten the screw as shown in Fig. 10 so that the bracket cannot turn.

8 Securing the Wire

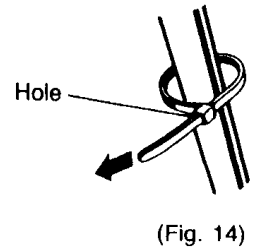
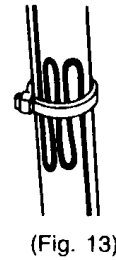
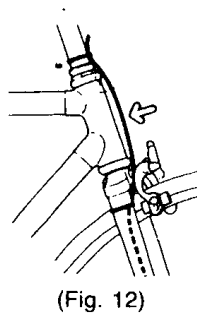
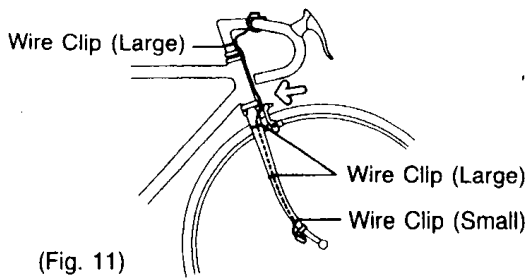

Clamp the wire with wire clips as shown in Fig. 11, 12. Loosen the wire in the area marked with the arrow (\rightleftarrows) so that the wire does not hinder handlebar operation. Fold the excess wire at the clip area as shown in Fig. 13. Pass the clip end through the clip hole as shown in Fig. 14, and firmly pull the end with pliers or similar tool. Cut off the projecting part of the clip.

9 Main Unit Mounting

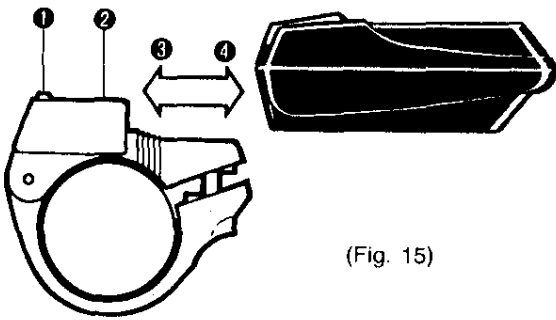

(Fig. 15)

Slide the main unit from the front to engage the lock hook of the main unit into the bracket groove. Be sure to click the projection of the bracket into the depression of the main unit. The contacts are automatically connected. To remove, pull the main unit forward and off.

- ① Projection
- ② Contact
- ③ Insert
- ④ Remove

10 Test

Mount the main unit on the bracket. Clear the front wheel off the ground and spin the wheel to check that the speed is displayed.

11 How to read data

Basic Data

- (a) Check that the speed scale symbol (mile/h or km/h) is not flickering. (Set the operation on stop.)
- (b) Select any mode except total distance (ODO), and press the mode button and start/stop button simultaneously. (Maximum speed (MXS), trip distance (DST), average speed (AVS) and elapsed time (TM) should be zero.)
- (c) Press the start/stop button when starting.
("mile/h (Km/h)" will flicker.)
- (d) Press the start/stop button when reaching your destination. (The speed scale symbol stops flickering, and the unit enters the stop state.)
- (e) Press the mode button to read the data.

Application of data

- (a) To accumulate actual trip data during a tour, resting time can be eliminated by pressing the start/stop button before and after resting.
- (b) To check lap time and maximum speed data on a track, press the start/stop button when passing the start line and again, when passing the finish line.

12 Trouble Shooting

The following situations do not indicate malfunction of the CYCLOCOMPUTER.
Check the following before taking it for repairs.

Trouble	Check Items	Remedy
The entire liquid crystal screen is dark and unusual display is seen where it should not be.	Wasn't it left for a long time under direct sun?	It returns to normal state if left in the shade. No adverse effect on data.
Display response is slow.	Isn't it at a low temperature under 32°F (0°C)?	It returns to normal state when temperature rises.
No display	Hasn't the Lithium Battery worn out?	Replace the Lithium Battery with a new one.
Incorrect data appears		Execute "All Clear" operation (Page 8).
Current speed does not appear.	Isn't there anything on the contact of the main unit or of the bracket?	Wipe the contact clean.

Trouble	Check Items	Remedy
Current speed does not appear.	Isn't the distance between sensor and magnet too far?	Refer to "Magnet/Sensor Mounting" (Page 12) and re-adjust correctly.
	Are the marking line of the sensor and the center of magnet matched each other?	
	Isn't the wire broken?	Connect and solder the wire, keeping correct insulation between the 2 wires. Or, replace the Bracket & Sensor part with a new one.

Precautions

- (a) Do not leave the main unit exposed to direct sunlight when the unit is not in use.
- (b) Do not disassemble the main unit or its accessories.
- (c) Don't pay too much attention to your Vectra's functions while riding! Keep your eyes on the road and give due consideration to traffic safety.

Specifications			
Functions	Current Speed	SPD	0 (3) ~ 65 miles/h (27 inches) 0 (4) ~ 105 km/h
	Maximum Speed	MXS	0 (3) ~ 65 miles/h (27 inches) 0 (4) ~ 105 km/h
	Total Distance	ODO	0.0 ~ 9999.9 miles or km
	Trip Distance	DST	0.00 ~ 999.99 miles or km
	Average Speed	AVS	0.0 ~ 65.0 miles/h 105.0 km/h
	Elapsed Time	TM	0:00'00" ~ 9:59'59"
Controller	4-bit 1-chip Microcomputer (Crystal Controlled Oscillator)		
Display	Liquid Crystal		
Sensor	No Contact Magnetic Sensor		
Power Supply	Lithium Battery (CR2032) × 1		

Specifications		
Operating Temperature Range		0°C ~ 40°C (32°F ~ 104°F)
Storage Temperature Range		- 20°C ~ 50°C (- 4°F ~ 122°F)
Applicable Cycle Sizes		16½" ~ 28½"
Standard Accuracy	Current Speed	±1 mile/h or km/h under 31 miles/h (50 km/h)
	Maximum Speed	±1 mile/h or km/h
	Total Distance	±0.1 mile or km
	Trip Distance	±0.01 mile or km
	Average Speed	±0.2 mile/h or km/h
Elapsed Time		±0.003 %
Battery Life		Approx. 2 ~ 3 years <small>The life of the first factory loaded battery may be shorter than this period</small>
Dimension/Weight		2-3/16" × 1-13/16" × 27/32" (56 × 46 × 21 mm)/1.34 oz. (38 g)

The specifications and design are subject to change without notice.